



MODEL №: 0345

ISSUED: JUL 2005

REVISED: 30 MAR 2022

SURFACE MOUNTED HORIZONTAL LIQUID SOAP DISPENSER

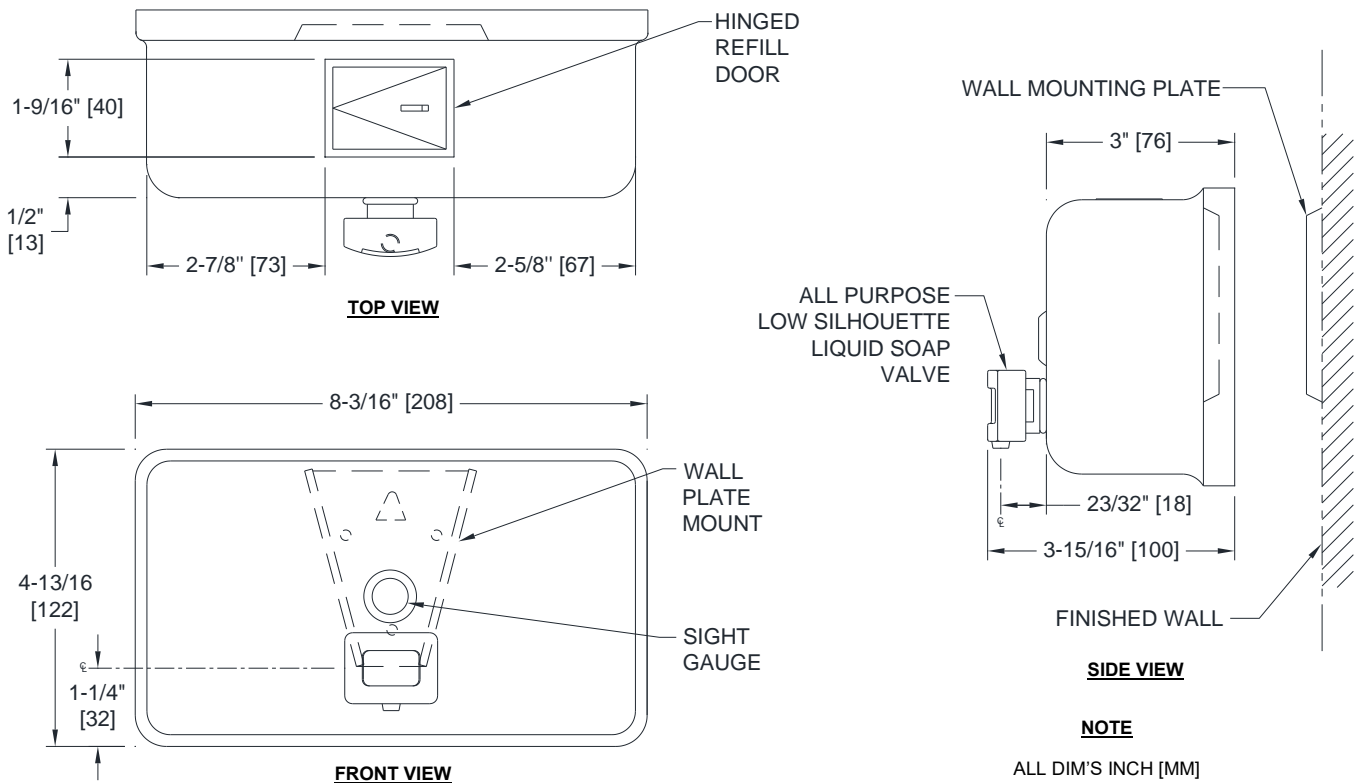

NOTE

ALL DIM'S INCH [MM]

ILLUSTRATION FOR REF ONLY AND NTS

SEE SOAP DISPENSER CARE & MAINTENANCE DOCUMENT
ONLINE FOR CLEANING

SPECIFICATION

Surface Mounted Horizontal Soap Dispenser shall have a capacity of 40 oz (1.2 L) of liquid soaps having a pH in range 7 ± 1.5 and viscosity in range 100-3500 cP (mPa·s). Soaps containing reportable salts, chlorides and alcohols should be avoided. Dispenser shall be fabricated of 20 gage type 304 stainless steel, alloy 18-8. All exposed surfaces shall be satin finish (or Powder Coated (PC) Matte Black finish if suffix -41 is added to Model №). Valve shall be a plastic valve body and push button with stainless steel and plastic internal parts. Valve operation shall comply with 2010 ADA Accessibility Standards and ANSI A.117.1 by requiring no more than 5 lbs_f (22.2 N) pressure to actuate and require no grasping or twisting by operator. A tamper resistant sight gauge shall be provided. Unit shall have a hinged stainless steel refill door on top of unit, which is opened with special key provided.

Surface Mounted Horizontal Soap Dispenser shall be Model № 0345 (add -41 for PC matte black) of American Specialties, Inc., 441 Saw Mill River Road, Yonkers, New York 10701-4913

INSTALLATION

Unit is surface mounted to wall or partition with a wall mounting plate (supplied) and screws (by others). Unit is secured to interlocking wedge bracket and locked in place by a locking screw (supplied) installed through hinged refill door. Recommended installation for general utility is 42" [1066] AFF (Above Finished Floor) or 6" [152] min above washbasin. For compliance with 2010 ADA Accessibility Standards and 2015 ABA Standards install unit with centerline of valve button no higher than 48" [1219] AFF.

OPERATION

Push button to dispense soap. Unit is refilled through hinged door at top requiring special key (supplied) to open. Soap tank will continue to feed properly until soap level is below valve intake port. Tank supply is replenished manually on cycle determined by maintenance needs.