



MODEL №: 0339

ISSUED: 17 SEP 2019

REVISED:

TOP-FILL FOAM SOAP DISPENSER

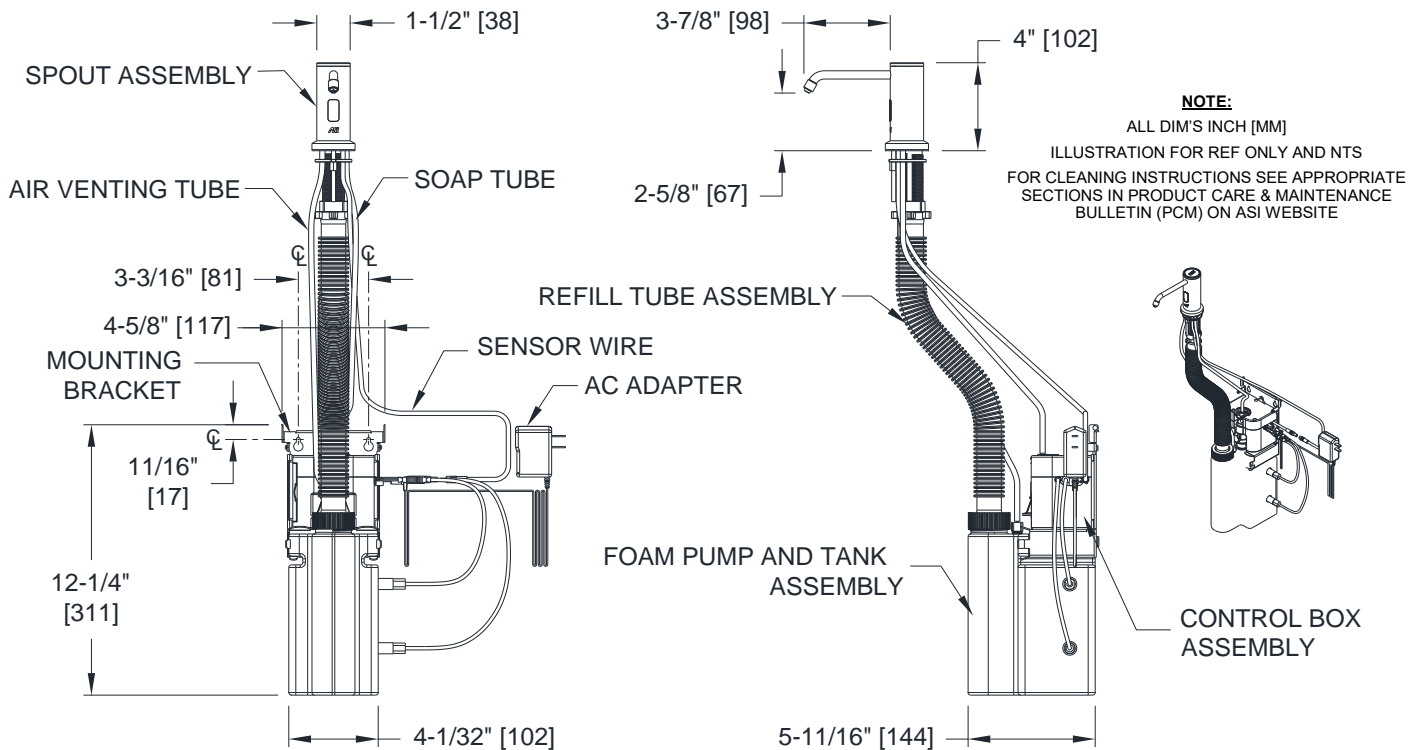

SPECIFICATION

Top-Fill Foam Soap Dispenser shall hold and dispense foaming soaps having a pH in range 7 ± 1.5 and viscosity in range 1-100 cP (mPa•s) from supply tank below pump housing with a capacity of 50.7 oz (1,5 L). Dispenser spout body shall be type 316 stainless steel and all exposed stainless steel surfaces shall be bright finish. Dispenser shall be powered by the AC adapter (supplied) and shall operate automatically from IR sensor that shall activate soap dispensing when hands are placed in sensor zone. Sensor detection range shall be preset at $4-3/4" \pm 1-1/2"$ [121 ± 38] and shall self-compensate for lighting conditions. An indicator LED shall provide status notification of battery condition, soap level and condition, and user sensor detection. Unit is equipped with an overflow protection feature and shall dispense a volume of .02 ~ .026 fl oz (0,6 ~ 0,8 ml) of foam soap during each activation. Supply tank installed under vanity is translucent with graduated markings to continuously provide soap level indications. An Owner's Manual (OM) and Mounting Template (MT) shall be provided with unit in carton.

Top-Fill Foam Soap Dispenser shall be Model № 0339 of American Specialties, Inc., 441 Saw Mill River Road, Yonkers, New York 10701-4913

INSTALLATION

Mount unit to counter top with washers and basin nut (supplied) through 1-1/2" Dia. [Ø38] hole in counter top to suit site conditions. Install pump control module with supply tank under vanity as per MT provided. Installation and Operation Instructions (OM № 1905270332) and Mounting Template (MT № 1902271650) are provided with unit in carton.

OPERATION

Foam soap is automatically dispensed when hands are placed in sensor zone. LED indicator flashes once to indicate detection of object in sensor zone. Diagnostic constant or green or red LED flashes indicate battery and/or soap condition (see OM for full description). Soap dispenser will continue to feed properly until empty. Tank supply is replenished manually on a cycle determined by maintenance needs. When filling the tank, the top level sensor will sound the buzzer when maximum soap level is reached, to advise service tech to stop filling so as to avoid overfilling. See OM for complete maintenance and refilling instructions.