



MODEL №: 20365

ISSUED: 09 JUN 2010

REVISED: 21 OCT 2021

AUTOMATIC FOAM SOAP AND FOAM SANITIZER DISPENSER

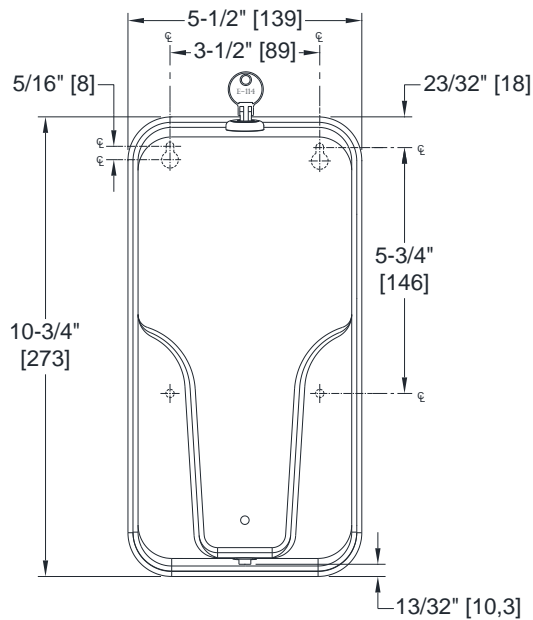

FRONT VIEW

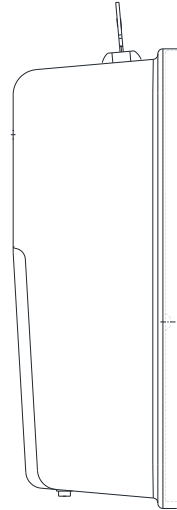

SIDE VIEW

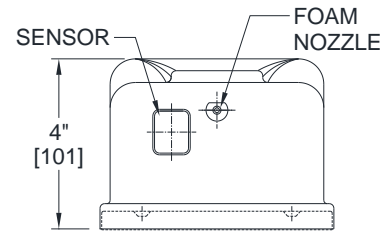

BOTTOM VIEW

NOTE:

ALL DIM'S INCH [MM]

ILLUSTRATION FOR REF ONLY AND NTS
SEE SOAP DISPENSER CARE & MAINTENANCE
DOCUMENT ONLINE FOR CLEANING

SPECIFICATION

Automatic Foam Soap Dispenser shall hold 34 oz (1 L) of liquid foaming soaps or foaming hand sanitizer having a pH in range 7 ± 1.5 and viscosity in range 1-50 cP (mPa•s) and dispense in cycles of single shot foam volume ranging from 1-4 oz to 1/3 oz [7 ml ~ 9 ml] using 0.02 oz ~ 0.03 oz [0.7 ml ~ 0.9 ml] liquid for each shot. Operation is initiated by hands-free sensor controlled by microprocessor digital circuitry powered by four (4) AA size 1.5 V batteries (supplied by others) in a concealed compartment and locked inside unit housing. Unit shall be fabricated of 22 gage type 304 stainless steel alloy 18-8 (.031" [0,8] thick) with a uniform satin finish over all exposed surfaces. Cover shall have lock keyed alike with other ASI washroom accessories. Unit shall have an LED to indicate function and operational condition on front face. Internal tank shall be translucent to show quantity of soap remaining at any time when cover is opened and shall be easily removed to facilitate filling and external storage of full tanks. Unit shall mount to wall on concealed base plate with screws secured under locked cover. Mounting Template (MT) and Owner's Manual (OM) shall be provided with unit in each carton.

Automatic Foam Soap and Foam Sanitizer Dispenser shall be Model № 20365 of American Specialties, Inc., 441 Saw Mill River Road, Yonkers, NY 10701-4913

INSTALLATION

Secure concealed base plate to wall with four (4) self-tapping screws (supplied by others: two (2) № 8 x 3/4" (M4.5 x 20) pan head & two (2) № 8 x 3/4" (M4.5 x 20) flat head) through mounting holes provided in plate into plastic wall anchors (by others) or other suitable mounting system (by others). Alternatively, unit may be installed on stand (Model № FS-0300) with mounting hardware supplied with stand. Install four (4) AA size 1.5 V cells (supplied by others) in concealed battery compartment according to polarity indication and snap-latch battery door. Fill tank with appropriate viscosity soap or sanitizer to correct level and lock door. Locking door activates concealed button to initiate operation. Retain key provided for future access. See OM for complete set up and operation instructions.

OPERATION

Unit shall operate each time an object is positioned within the sensing distance of 3-1/8" [80] \pm 3/8" [10] from unit bottom. A foam mass of 1-4 oz to 1/3 oz [7 ml ~ 9 ml] or similar volume of foaming hand sanitizer will be pumped out of the nozzle on unit bottom for each activation while batteries are at suitable charge level (LED is not flashing) and correct viscosity liquid foaming soap or foaming sanitizer is present in the tank. Door has lock to provide security and vandal resistance after each foaming soap or foaming sanitizer refill and battery change service interval. Make sure to wash out tank & pump completely if changing from foaming sanitizer to foaming soap or vice versa.

www.hygiene-shop.eu - info@hygiene-shop.eu