

# Model 0394-(n)\*



EZFILL™ FOAM SOAP DISPENSER

AUTOMATIC DECK MOUNTED  
FOAM SOAP DISPENSER FOR  
STANDALONE USE

INSTALLATION AND MAINTENANCE GUIDE

# TABLE OF CONTENTS

- 2 SUFFIX CODE INDEX AND APPLICATION
- 3 PRE-INSTALLATION INFORMATION
- 4 PACK CONTENTS
- 5 TECHNICAL DATA
- 6-7 INSTALLATION
- 8 FILLING THE BOTTLE AND PRIMING THE FOAM SOAP DISPENSER
- 9 BATTERY REPLACEMENT INSTRUCTIONS
- 10 TROUBLESHOOTING
- 11 SPARE PARTS LIST
- 11 MAINTENANCE
- 12 WARRANTY
- 13-14 EZ FILL™ FOAM REMOTE CONTROL

Unit Install Date \_\_\_\_\_  
Unit Location in Facility \_\_\_\_\_  
Unit S/N (From Label) \_\_\_\_\_  
Supplied By \_\_\_\_\_  
Original PO No. \_\_\_\_\_  
ASI Order No. \_\_\_\_\_

# \*SUFFIX CODE INDEX AND APPLICATION

Schedule of Model N° Suffix Codes to replace (n) in Model N° and Application	
Model N° Suffix	Service Application
1A	Universal Model, Battery Operation
1AC	USA/UK/EU Interchangeable Plug Model, AC Adapter Operation
3AC	AU Model, AC Adapter Operation
6-1A	Universal Model, Battery Operation, Six Pack
6-1AC	USA/UK/EU Interchangeable Plug Model, AC Adapter Operation, Six Pack
6-3AC	AU Model, AC Adapter Operation, Six Pack

Space Provided For Owner Notes

# PRE-INSTALLATION INFORMATION

## CHECK CONTENTS

Separate all parts from the packaging and check each part with the PACK CONTENTS section.

Make sure all parts are received and separated before discarding any packaging material.

If any parts are missing, do not attempt to install the system until you obtain the missing parts.

## IMPORTANT

Ensure there is adequate space and clearance under the vanity to accommodate the SD Mounting Shank and Basin Nut in the desired location before drilling the hole in the counter top.

Ensure there is adequate space to place the Pump, Compressor and Bottle Support Bracket within reach of the Com Cable from the SD Shank.

Keep in mind that the location of the user hands, while using the faucet nearby, should not interfere with the soap dispenser sensor detection area.

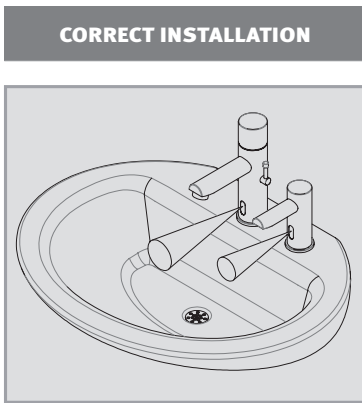

**CORRECT INSTALLATION**

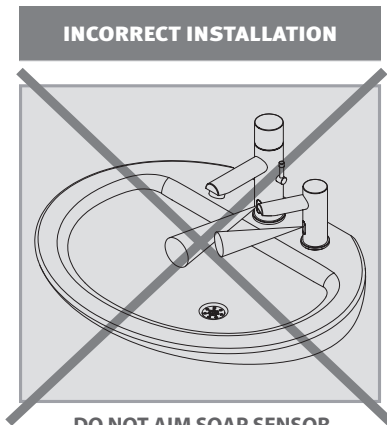

**INCORRECT INSTALLATION**

**DO NOT AIM SOAP SENSOR AT WATER STREAM**

## CAUTION

Do not install the foam soap dispensers facing a mirror or any other electronic system operated by an infrared sensor.

To prevent reflection problems, it is recommended to keep a minimum distance of 6" (150 mm) between the foam soap dispenser sensor and any other directly facing objects.

# PACK CONTENTS

## EZFILL™ FOAM SOAP DISPENSER 0394-(n)

Identify the items and confirm that parts are included.



Automatic Foam SD Body and vanity mounting hardware with power cord, Com Cable w/inline plug connector and foam soap supply tube.

Foam Compressor with straight foam tube connector, L-connector and soap delivery tube, Com Cable with inline socket connector for dispenser head, Com Cable with inline plug connector for pump

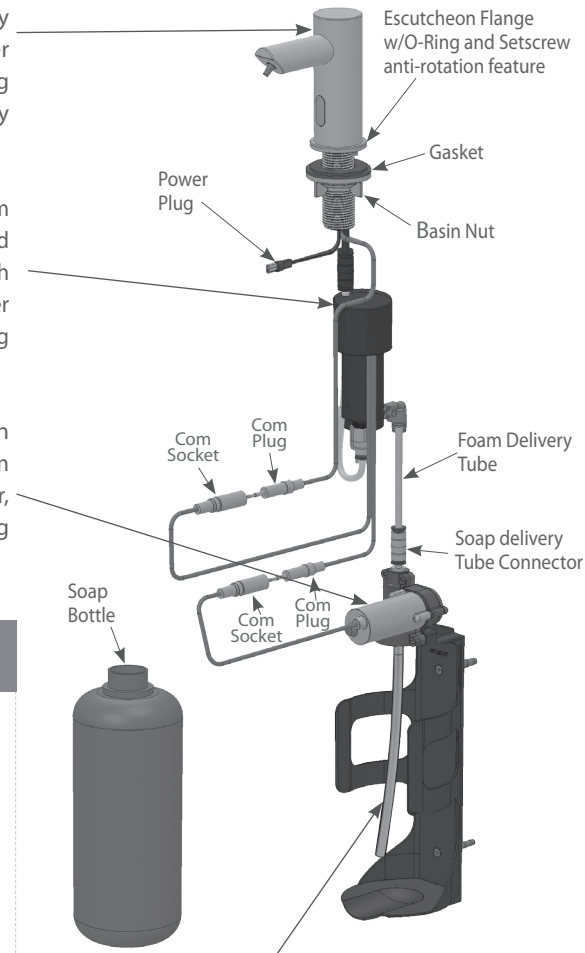
EZFILL™ pump assembly with bottle support wall bracket, Com Cable w/inline socket connector, soap supply tube and mounting hardware.



**Power Supply Option**

	
Battery Box 6X1.5V D batteries	Transformer 12V from 100~240 VAC

**Only one option per model**

**Batteries not included**

Clear 5/16" dia. (Ø8) Soap Supply Flex tube 9" (230) Supplied permanently attached to pump housing.

# TECHNICAL DATA

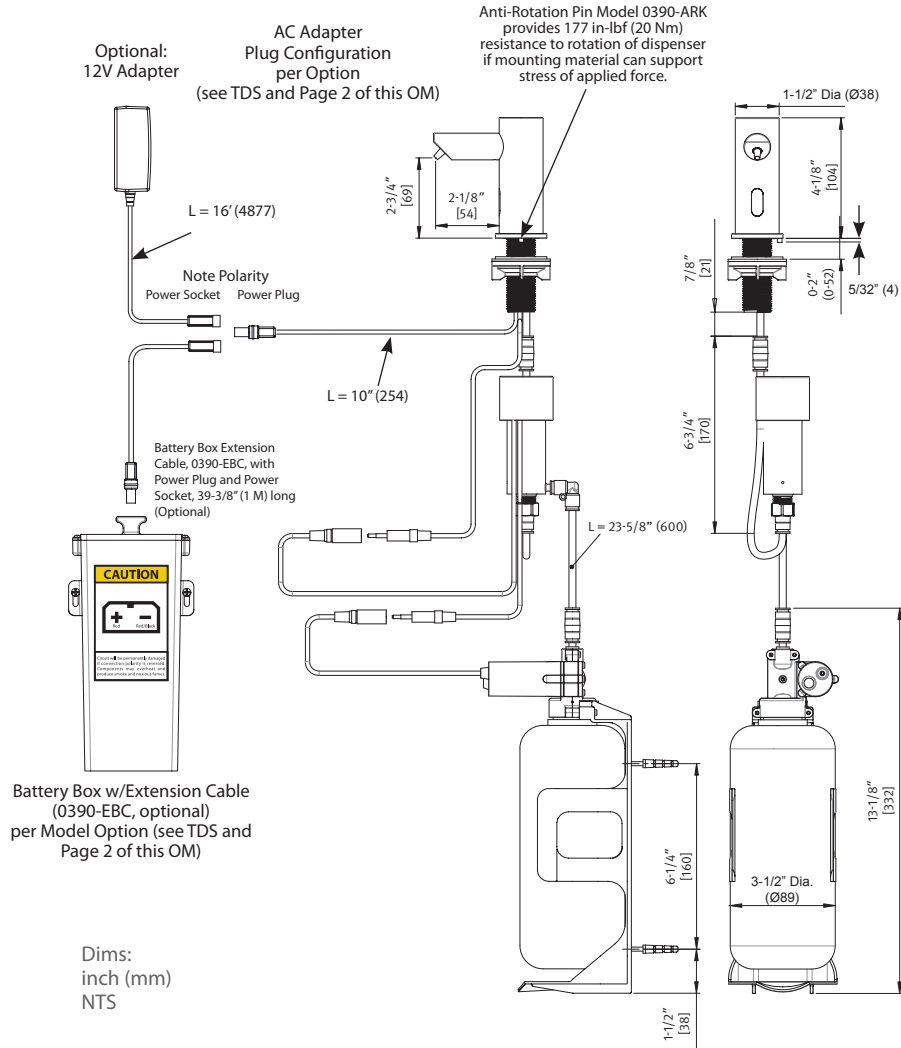

Model 0394-(n) EZFILL™ Foam Soap Dispenser and Soap Pump for standalone operation with 33.8oz (1L) bottle

Soap Viscosity	Soap pH	Soap Type
Max 100 cPs (mPa·s)	5.5 – 8.5	clear foaming liquid, no abrasives

# INSTALLATION

## INSTALLING THE EZFILL™ FOAM DISPENSING SYSTEM SOAP DISPENSER

1

Drill a 1" Dia [Ø25] hole through the counter top at the designated location for the dispenser body. Drill 3/16" (5) deep hole for the anti-rotation pin. Remove and retain the basin nut and gasket from the base of the soap dispenser body, sliding completely over and off the soap tube, Com and Power Cables.

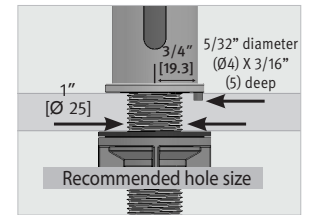

2

Place the soap dispenser shank through the escutcheon flange (with O-ring down) into the hole in the counter top. Be careful to locate the anti-rotation pin into pre-drilled hole so that alignment is permanently fixed. Slide the metal washer, rubber disk, then nut over the black soap tube and both cables and thread onto the shank and secure it to deck underside.

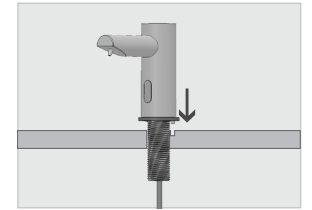

3

Connect the foam compressor to the tube extending down from the shank by pushing the straight connector up onto the tube until fully engaged. **IMPORTANT:** the foam dispenser compressor **MUST** be installed as shown in the picture. This position prevents dirt and debris buildup. Insert the dispenser head Com Plug into the compressor Com Socket. Please note that since the connector is water proof, some pressure must be applied for a perfect seal.

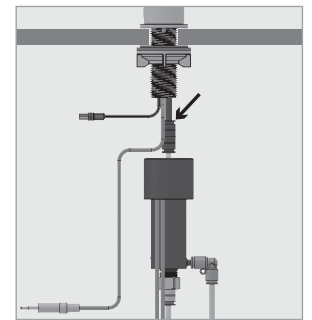

4

**IMPORTANT:** the 4 contacts connector should be inserted fully so that the white O-ring is not visible and a clicking sound is heard when fully engaged.

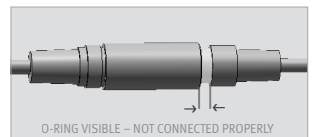

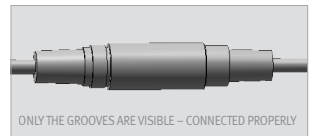

**NOTICE:** If the 4 contacts connectors are not connected properly, the motor will run continuously.

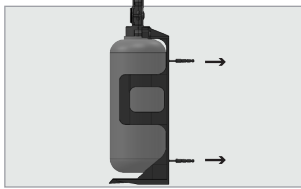
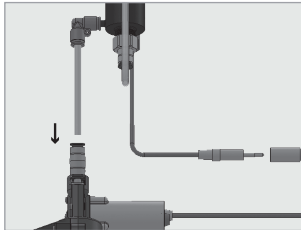

# INSTALLATION

# FILLING THE SOAP BOTTLE AND PRIMING THE FOAM SOAP DISPENSER

<p><b>5</b></p>	<p>Attach the bottle support and soap pump to the desired location by securing the support with the supplied screws. The pump <b>MUST</b> be within reach range of the Com cable and black supply tube.</p>	
<p><b>6</b></p>	<p>Connect the compressor com plug to soap pump com socket and connect the black supply tube from the compressor to soap pump via the soap supply tube connector. The supply tube can be cut in the field to suit under-counter space conditions</p>	
<p><b>7</b></p>	<p>Remove the protective sticker covering the sensor. Keep hands, tools and other objects away from the sensor range.</p>	

## CONNECTING THE POWER SOURCE

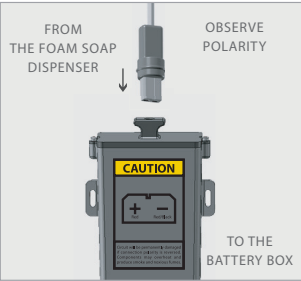
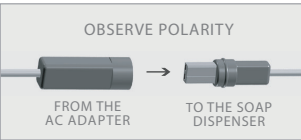
<p><b>8</b></p>	<p>A. For battery versions: Insert six (6) 'D'-size alkaline batteries into the battery box. Be sure to observe polarity configuration. Install the battery box at the wall underneath the sink and connect the battery connector. More freedom of location may be obtained with use of Optional 0390-EBC extension cable. Ensure adequate clearance to allow removal of the top cover and the battery carrier tray when a battery change is required.</p>	
	<p>B. For AC Adapter versions: plug the adapter into the power socket and connect the adapter DC connector to the power plug from the soap dispenser.</p>	

## STEP 1 - FILLING THE SOAP BOTTLE

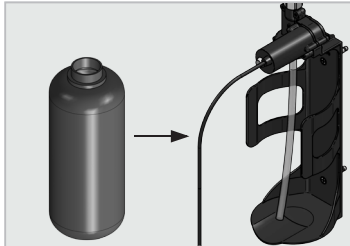
<p><b>1</b></p>	<p>Remove the soap bottle from the EZFILL™ foam soap dispenser bracket and pour liquid foaming soap into container until it is full. Refer to 'Technical Data' section of this manual for soap specifications. (Page 5)</p>	
<p><b>2</b></p>	<p>Should any soap spill over the outside of the bottle, clean it thoroughly. Replace clean soap bottle into original position in the EZFILL™ soap dispenser bracket. Hand screw-tighten until snug up into bracket - bottle receiver.</p>	

## STEP 2 - PRIMING THE SOAP DISPENSER

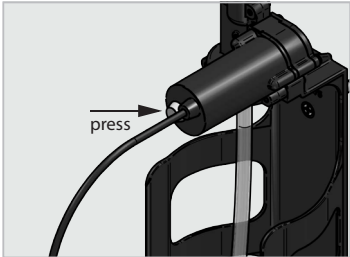
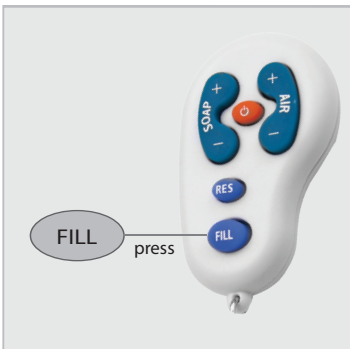
<p>Option 1</p>	<p>Press and hold the fill button located on the EZFILL™ foam soap dispenser pump until soap is observed dispensing from spout. Release button to stop priming.</p>	
<p>Option 2</p>	<p>Optionally, press (once) the fill function on the soap dispenser remote control while pointing at the blue LED in the sensor. Priming will last 1 minute. Press the fill button (once) again if no soap comes out after the 1 minute time limit is over. Press "FILL" button again if foam is dispensing before prime time-out to stop. See SETTINGS ADJUSTMENT in 0393-R operation manual for additional functions (Pages 13-14).</p>	

# BATTERY REPLACEMENT INFORMATION

## Battery models only

To replace the batteries:

1. Carefully open the battery box, use Philips drive #2 to remove cover screws (Fig. 1&2, below)
2. Remove the old batteries from carrier tray (Fig. 3)
3. Replace the used batteries with new D-size batteries in same polarity (Fig. 3)

**NOTE:** Do not mix used batteries with new ones. Do not use rechargeable batteries.

4. Close the box, re-tighten the screws (Fig. 4) and reconnect battery cable.

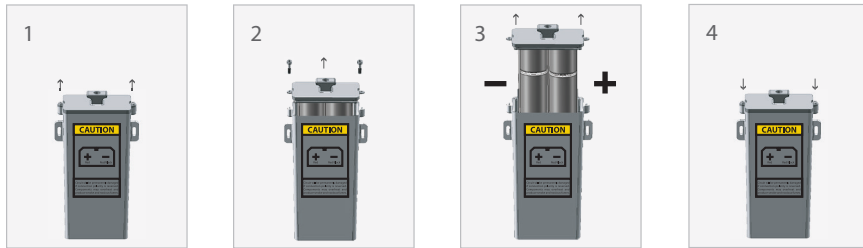

Important: spent batteries should be recycled as industrial waste. Contact your local authority for information on waste disposal and recycling.



# TROUBLESHOOTING

PROBLEM	INDICATOR	CAUSE	SOLUTION
Foam does not come out of the spout	Blue light in the sensor flashes (once) and the motor is operating.	Soap has run low or completely out.	Refill the soap tank. <i>Refer to page 8</i>
		The soap tank has been filled but soap has not reached the spout.	Press the refill button located on the soap dispenser pump or on the FILL button on the remote until soap starts to come out of the spout.
		The connectors between foam dispenser head dispenser pump, compressor unit and the foam dispenser head unit are not connected properly.	Connect the inline Com Cable connectors properly so that the white o-ring is not visible.
		The filter is clogged.	Clean or replace the compressor filter.
Foam is too diluted	Blue light in the sensor does not flash (once) when the user's hands are within the sensor's range.	Sensor is picking up reflections from the washbasin or another object.	Eliminate cause of reflection.
		Connectors between the foam dispenser head unit and power source are disconnected or not properly connected.	Connect the foam dispenser head power connector to the power source connector.
Foam is too dense		Air ratio too low	Increase air ratio using the remote control. (sold separately) <i>Refer to page 14</i>
		Air ratio too high	Decrease air ratio using the remote control. (sold separately) <i>Refer to page 14</i>
Soap dispenser pump does not work	Blue light flashes (once) and the foam compressor operates.	The connectors between the soap dispenser pump and the foam compressor are not connected properly.	
Soap compressor does not work	Blue light flashes (once) and the motor operates.	The connectors between the compressor and the electronic unit are not connected properly.	Connect the inline Com Cable connectors properly so that the white O-rings are not visible.
Soap coming out of the spout does not stop		The connectors between the motor and the compressor are not connected properly.	
		The connectors between the compressor and the electronic unit are not connected properly.	

## SPARE PARTS LIST

EZFILL™ AC Adapter 12V (US, UK, & EU) .....	0390-ACA
EZFILL™ AC Adapter 12V (AU) .....	0390-ACA-3
EZFILL™ Anti-Rotation Kit.....	0390-ARK
EZFILL™ Battery Pack (Batteries not included) .....	0390-BP
EZFILL™ Battery Pack (0390-BP) Extension Cable/1M Male to Female Connectors .....	0390-EBC
EZFILL™ Soap Pump .....	0390-P
EZFILL™ 180° Quick Connector .....	0390-QC
Mounting Bracket for EZFILL™ Soap Pump & 1 Liter Container .....	0391-PBR
EZFILL™ 1 Liter Container Only .....	0391-SB
EZFILL™ Air Compressor.....	0393-C
EZFILL™ Filter for Air Compressor .....	0393-F
EZFILL™ 90° Quick Connector and ¼" Dia. [Ø6 mm] Plastic Pipe 24" [610 mm] long .....	0393-QC
EZFILL™ Remote for Foam Dispensers .....	0393-R

## MAINTENANCE

Care and cleaning of chrome and special finishes- see also PCM document.

**DO NOT** use steel wool or cleansing agents containing alcohol, acid, abrasives, or the like. Use of any cleaning or maintenance products containing these substances could damage the surface of the soap dispenser. For surface cleaning use **ONLY** soap and water, then wipe dry with a clean cloth or towel. When cleaning bathroom tiles or counters, protect the soap dispenser from any splattering of harsh cleansers.

### Filter cleaning instructions:

The foam soap dispenser's compressor is provided with a filter. It is recommended to clean the filter every six (6) months.

A decrease in soap supply may indicate that the the filter is clogged and requires cleaning. Cleaning instructions:

1. Disconnect the compressor from the soap dispenser body
2. Unscrew the nut at the bottom of the foam compressor and pull out the filter.
3. Wash the filter under running water.
4. Reassemble the parts.

**MAKE SURE THE SOAP CONTAINER IS CLEAN BEFORE FILLING IT WITH SOAP.  
DIRTY SOAP MAY CAUSE CLOGGING.**

## WARRANTY

We are pleased to offer this warranty covering ASI products furnished for your project.

This warranty replaces any other warranties or product descriptions, whether expressed or implied, written or oral.

It is understood that the products for this project have been selected and inspected by the purchaser, and have been accepted without qualification by the purchaser as merchantable, fit for the intended use, and satisfy the specifications.

**EZ FILL™ SOAP DISPENSER PRODUCTS WILL BE FREE OF DEFECTS IN MATERIAL AND WORKMANSHIP DURING NORMAL USE FOR (2) TWO YEARS FROM THE DATE OF INVOICE.**

Should the product fail under this warranty, the sole remedy, at the seller's option, will be to repair the defective product, refund the purchase price, provide an equivalent new or refurbished product or provide parts only.

ASI AND/OR SELLER DISCLAIM ANY LIABILITY FOR SPECIAL, INCIDENTAL OR CONSEQUENTIAL DAMAGES. This warranty excludes product damage due to incorrect installation, improper maintenance, wear and tear, battery spoilage, product abuse, or product misuse, whether performed by a contractor, service company, or the consumer.

ASI will not be responsible for labor costs associated with the removal, replacement, repair by others, reinstallation, renovation or return of its products.





EZFILL™ FOAM REMOTE CONTROL

REMOTE CONTROL FOR ALL MODELS  
0393-(n) and 0394-(n) Vanity Mounted  
Automatic Foam Soap Dispensers

FUNCTIONAL & OPERATIONAL GUIDE

## OPERATION

If desired, use the remote control to adjust the foam soap dispenser settings. Hold the remote control straight in front of the sensor in a distance of about 4-6" (10-15cm).

Attention: Holding the soap dispenser remote control out of the recommended range (too close or too far) may interfere with its activation.

### 1-SOAP VOLUME

Press the + sign at the SOAP button to increase the soap volume by increasing the dispensing time and the - sign to decrease it. Adjustable foam dispensing duration (min-max): 0.5-2.5 seconds  
Indication: continuous blinking blue light in the sensor eye.

### 2-SOAP CONSISTENCY

To improve the soap "foamability" change the amount of air to be mixed. Press the + sign on the AIR button to increase the air mixed with the soap and the - sign to decrease it.  
Indication: 2 blinks of the blue light in the sensor eye.

### 3-RES

This function resets the sensor back to factory settings: soap volume, soap consistency (foamability), soap tank refill, temporary off and reset.

### 4-TEMPORARY OFF FUNCTION

This function temporarily disables the dispenser and is ideal to perform any kind of activity in front of the sensor without operating the system (for example, cleaning). The soap dispenser will remain shut off for one minute when this button is pressed once. To cancel this function and to return to normal operation press the On/Off button again or wait one minute.

### 5-FILL THE SOAP TANK

Once the soap tank has been filled/refilled, press the FILL button. The pump will work for one minute in order to fill the piping with soap. To stop this activity press the FILL button again. If the soap has not started coming out of the spout, after 1 minute of priming press the FILL button again.  
Indication: continuous blue light in the sensor eye.

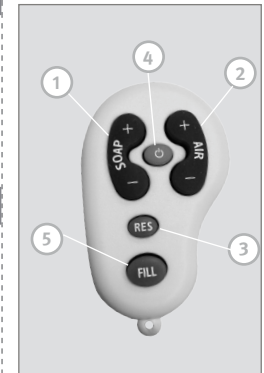

### Remote control battery

The remote control is powered by a CR2032 battery, with a life span of 4 years.

### Replacing the battery:

1. Remove the metal key ring using small pliers
2. Separate the two parts of the plastic cover. note the two plastic pins which connect the two cover parts
3. Gently push the old battery out of its support and replace it with a new one
4. Reassemble the remote



